

Package Dimensions

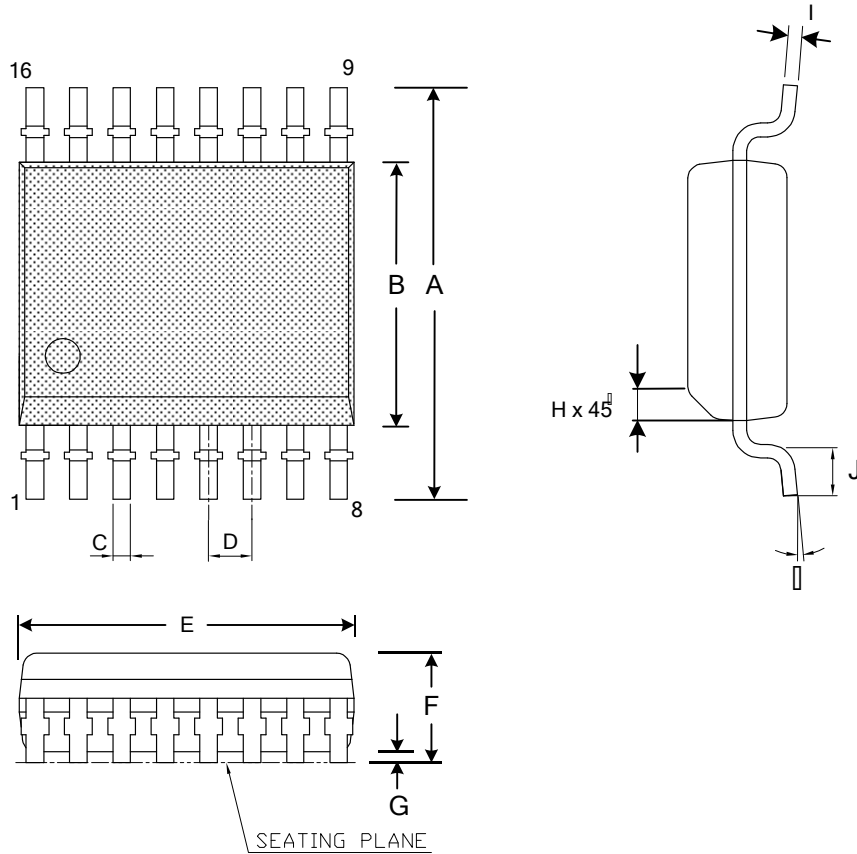

Table of Dimensions

No. of Leads		SYMBOL										
16		A	B	C	D	E	F	G	H	I	J	ϕ
Milli- meters	MIN	5.80	3.80	0.20	0.635	4.80	1.35	0.10	0.25	0.18	0.40	0°
	MAX	6.20	4.00	0.30		5.00	1.75	0.25	0.50	0.25	1.27	8°

16 Pin SSOP (150 Mil) Package